

SERVICE MANUAL

**DATSUN 240Z SPORTS
MODEL S30 SERIES**

CHASSIS & BODY



NISSAN

NISSAN MOTOR CO., LTD.
TOKYO, JAPAN

SECTION CL

CLUTCH

CL

CLUTCH	CL- 1
CLUTCH CONTROL	CL- 5
SERVICE DATA AND SPECIFICATIONS	CL- 9
TROUBLE DIAGNOSES AND CORRECTIONS	CL-11

CLUTCH

CLUTCH

DM

CONTENTS

DESCRIPTION	CL-1	Disc assembly	CL-3
REMOVAL	CL-2	Release bearing and sleeve	CL-4
DISASSEMBLY	CL-2	REASSEMBLY	CL-4
INSPECTION AND ADJUSTMENT	CL-2	Release mechanism	CL-4
Clutch assembly	CL-2	REINSTALLATION	CL-5

DESCRIPTION

The clutch is a single dry disc diaphragm spring type clutch. The major components are clutch cover, pressure plate, diaphragm spring, and wire rings. The clutch disc is provided with riveted plates on both surfaces and coil springs arranged in a link. The coil springs absorb shock while engaging the clutch, softening the smoothing clutch

engagement.

Release bearing, sleeve, and withdrawal lever are used to control clutch engagement and disengagement.

Each part of the clutch assembly is secured with rivets. Therefore, when a trouble is uncorrectable, replace the clutch assembly with a new assembly.

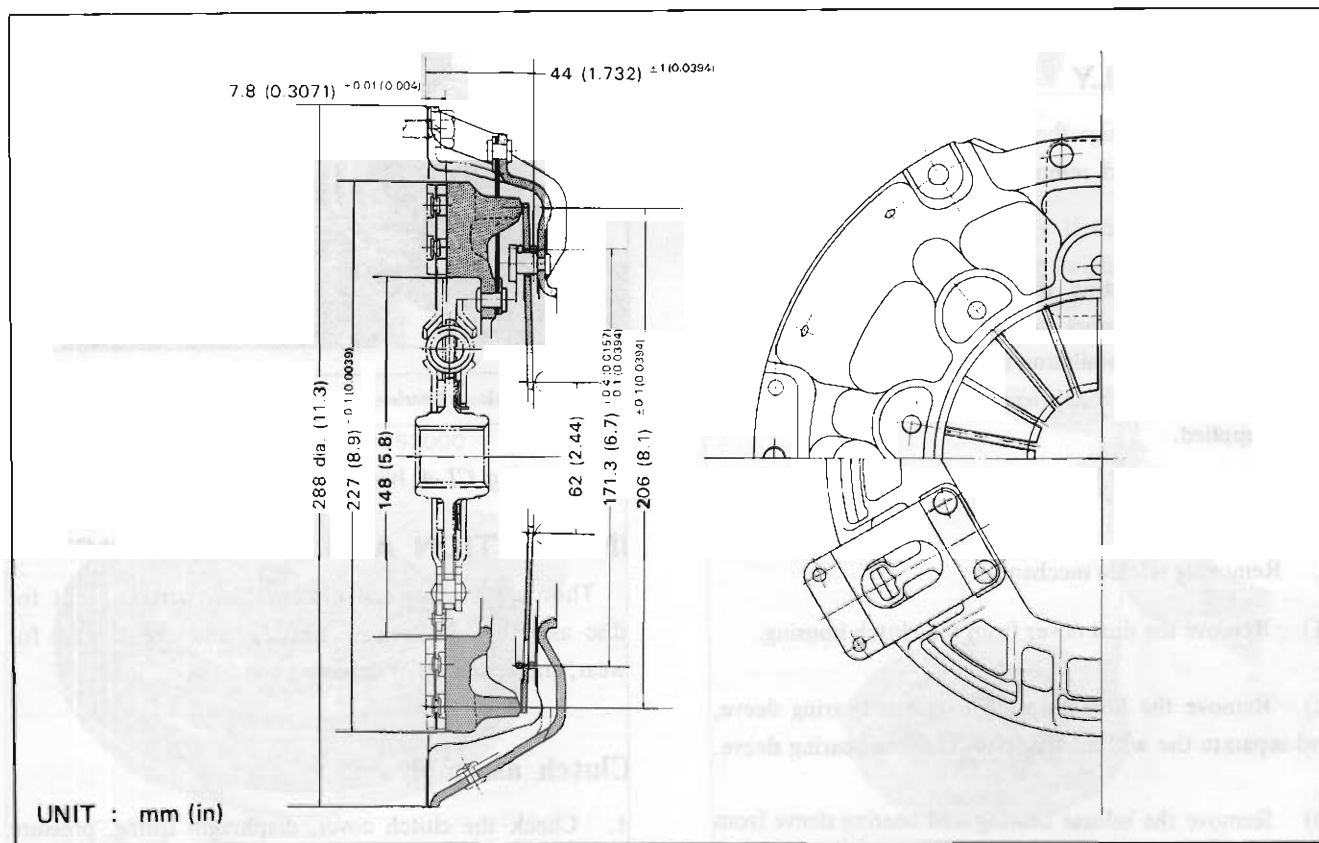
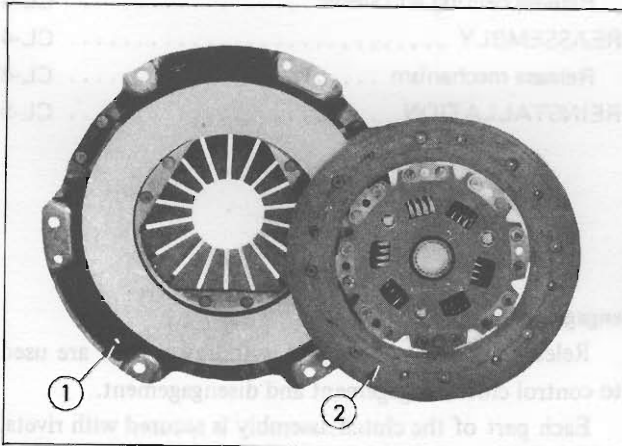

Fig. CL-1 Construction of clutch

CHASSIS

REMOVAL

The clutch assembly is dismantled primarily in the same manner as the engine assembly. Thus, when dismantling the clutch assembly, refer to the Section ER (Engine Removal) and other relative sections.



1	Clutch assembly	2	Clutch disc assembly
---	-----------------	---	----------------------

Fig. CL-2 Clutch assembly and disc assembly

DISASSEMBLY

1. When separating the clutch assembly from the flywheel, loosen and remove the installation bolts diagonally and gradually.

Note: When separating the clutch assembly from the flywheel, support the clutch cover sufficiently and loosen the installation bolts gradually and carefully because the diaphragm spring tension is always applied.

2. Removing release mechanism

- (1) Remove the dust cover from the clutch housing.
- (2) Remove the holder spring from the bearing sleeve, and separate the withdrawal lever from the bearing sleeve.
- (3) Remove the release bearing and bearing sleeve from the front cover, and remove the withdrawal lever from the withdrawal lever ball pin.

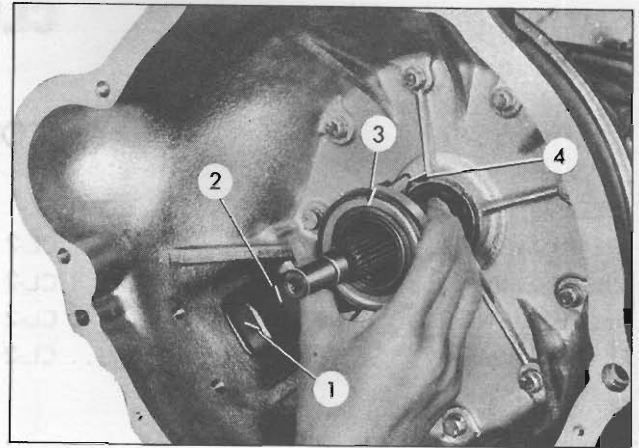

1	Dust cover	3	Release bearing
2	Withdrawal lever	4	Holder spring

Fig. CL-3 Disassembling release mechanism

3. Withdraw the release bearing from the bearing sleeve by the use of a bearing puller.

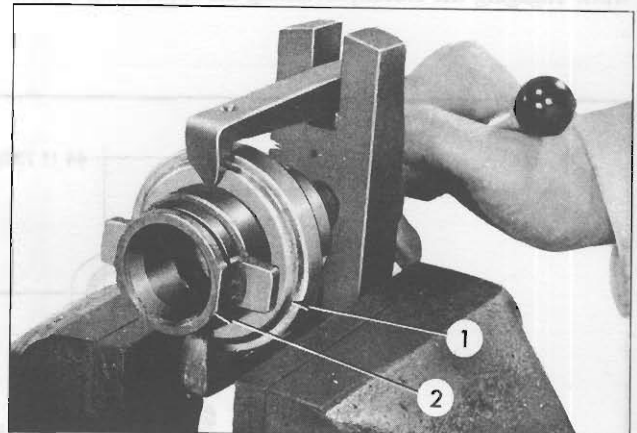

1	Release bearing	2	Bearing sleeve
---	-----------------	---	----------------

Fig. CL-4 Withdrawing release bearing

INSPECTION AND ADJUSTMENT

Thoroughly clean all disassembled parts, except for disc assembly and release bearing, and check them for wear, crack, and other defective conditions.

Clutch assembly

1. Check the clutch cover, diaphragm spring, pressure plate, etc. for excessive wear, crack and damage. When noise occurs on the clutch assembly, replace.

CLUTCH

2. Measuring and adjusting height of diaphragm spring

- (1) Line up distance piece (special tool ST20058001) on clutch assembly base plate (special tool ST20051000).

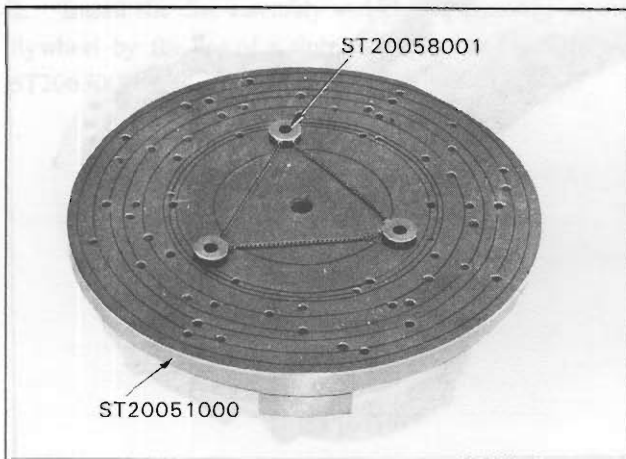

Fig. CL-5 Base plate and distance piece

- (2) Place the clutch assembly on the distance piece, and set the clutch assembly on the base plate stationarily. (Under this condition, the distance piece is placed beneath the pressure plate.)

- (3) Raise center pole (special tool ST20052000) on the base plate. Install height gauge (special tool ST20240000) on the pole, and measure height of the diaphragm spring end from the upper surface of the base plate.

Height of diaphragm spring end:

43.0 to 45.0 mm (1.693 to 1.772 in)

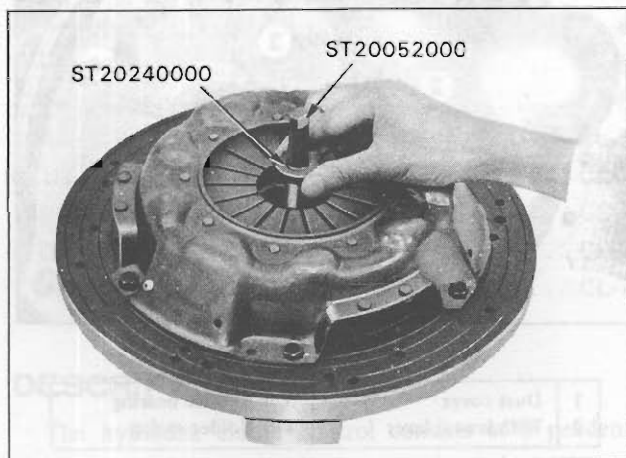

Fig. CL-6 Measuring height of diaphragm spring

Disc assembly

1. If the facing is soiled with grease or oil, clean off with gasoline tetrachloride and dress the facing with a wire brush. Replace the facing, if required.
2. Check the disc for deflection, and repair or replace if the deflection at the outer circumference of the facing exceeds the following value:

Upper limit of the deflection:

0.5 mm (0.0197 in) at
112 mm (4.40 in) radius

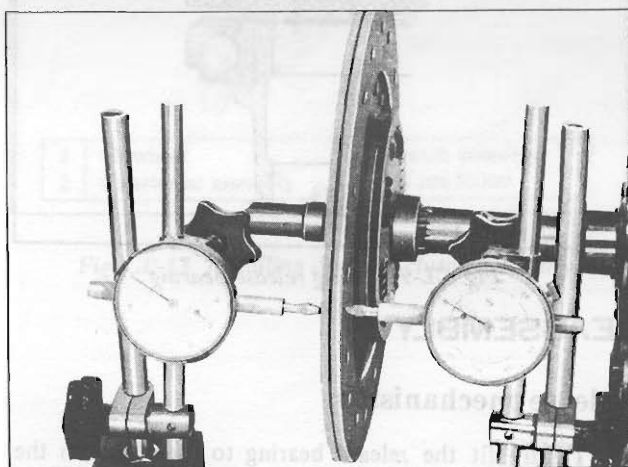

Fig. CL-7 Checking disc for deflection

3. Replace the disc assembly if the facing is worn to such an extent that the facing height above rivet is less than 0.3 mm (0.0118 in), the facing is worn unevenly, or rivets are loose.

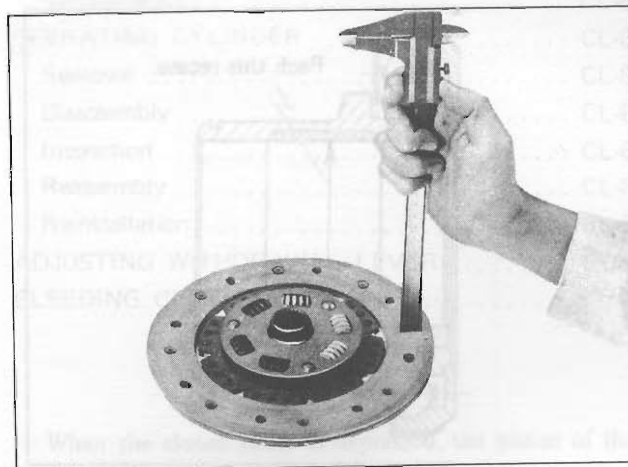

Fig. CL-8 Checking clutch facing for wear

CHASSIS

Release bearing and sleeve

1. When withdrawal lever and bearing sleeve contact point is worn in step, replace the sleeve.
2. When grease leaks from the release bearing, or noise occurs on the release bearing, replace the release bearing.

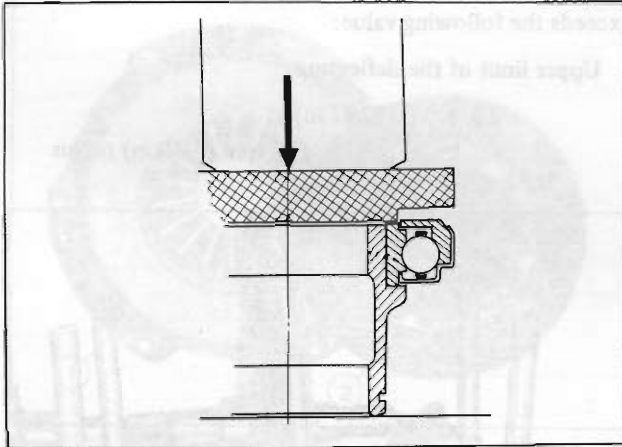

Fig. CL-9 Fitting release bearing

REASSEMBLY

Release mechanism

1. Tightly fit the release bearing to the place on the bearing sleeve as shown in Figure CL-9. When the bearing is installed completely, turn the bearing with a finger, and make sure that the bearing operates smoothly.
2. Apply multi-purpose grease (MIL G-2108 or 10924) to the following places:
 - Bearing sleeve inside groove

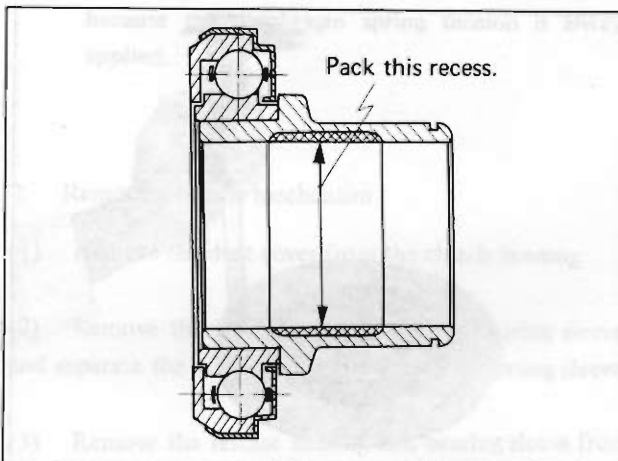
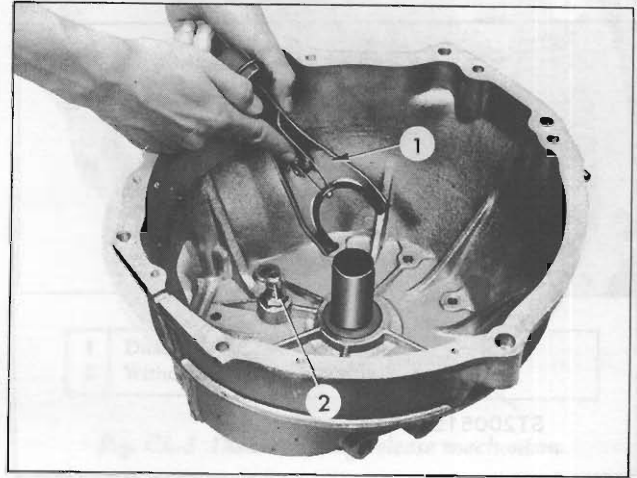

Fig. CL-10 Position on the bearing sleeve to which grease is applied

- Withdrawal lever and bearing sleeve contact point
- Withdrawal lever ball pin and withdrawal lever contact surface.



1	Withdrawal lever	2	Withdrawal lever ball pin
---	------------------	---	---------------------------

Fig. CL-11 Position on the withdrawal lever to which grease is applied.

3. When grease is applied to the necessary places, install the withdrawal lever, release bearing, and bearing sleeve on the clutch housing, connect them with holder spring, and install the dust cover on the clutch housing.

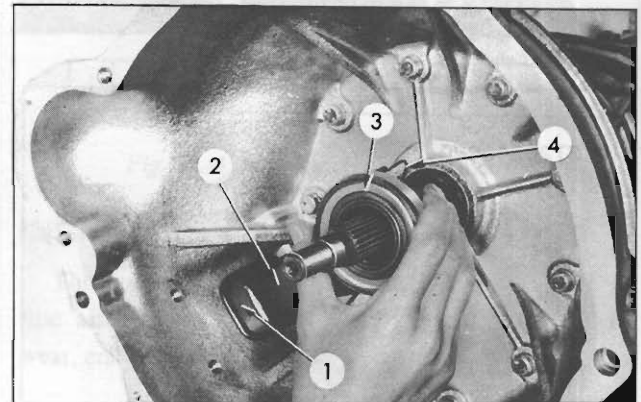

1	Dust cover	3	Release bearing
2	Withdrawal lever	4	Holder spring

Fig. CL-12 Installing release mechanism

CLUTCH

REINSTALLATION

1. Clean the clutch pilot bushing, and fill it with recommended multi-purpose grease.
2. Install the disc assembly and clutch assembly on the flywheel by the use of a clutch aligning bar (special tool ST20630000).

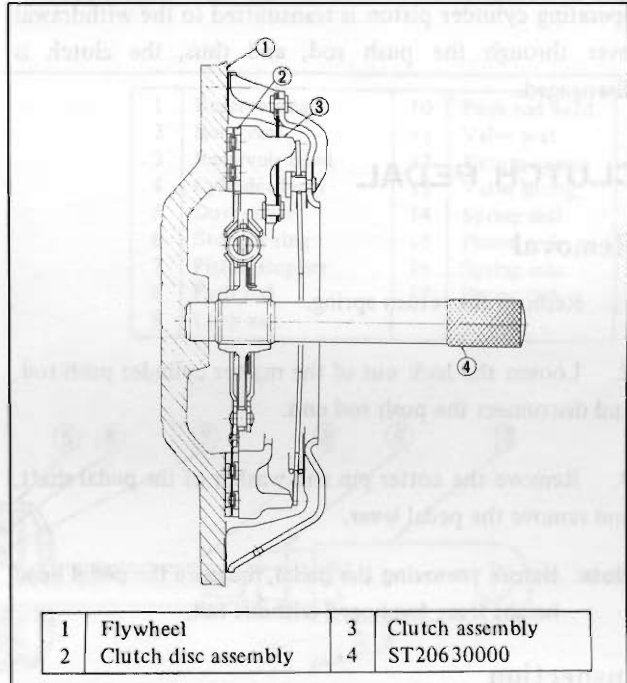

Fig. CL-13 Installing disc and clutch assembly

CLUTCH CONTROL

CONTENTS

DESCRIPTION	CL-5	Reassembly	CL-7
CLUTCH PEDAL	CL-6	Reinstallation	CL-8
Removal	CL-6	OPERATING CYLINDER	CL-8
Inspection	CL-6	Removal	CL-8
Reinstallation	CL-6	Disassembly	CL-8
Adjustment	CL-6	Inspection	CL-8
CLUTCH MASTER CYLINDER	CL-7	Reassembly	CL-8
Removal	CL-7	Reinstallation	CL-8
Disassembly	CL-7	ADJUSTING WITHDRAWAL LEVER	CL-8
Inspection	CL-7	BLEEDING CLUTCH SYSTEM	CL-9

DESCRIPTION

The hydraulic clutch control consists of a pendent pedal, master cylinder, operating cylinder and withdrawal lever.

When the clutch pedal is depressed, the piston of the master cylinder forwards the fluid to the operating cylinder through a pipe line. The movement of the

CHASSIS

operating cylinder piston is transmitted to the withdrawal lever through the push rod, and thus, the clutch is disengaged.

CLUTCH PEDAL

Removal

1. Remove the return spring.
2. Loosen the lock nut of the master cylinder push rod, and disconnect the push rod end.
3. Remove the cotter pin and washer of the pedal shaft, and remove the pedal lever.

Note: Before removing the pedal, measure the pedal head height from toe board without fail.

Inspection

Thoroughly clean all disassembled parts (indicated below) and carefully check them for wear, damage and other abnormal conditions. Repair or replace them with

new ones, if required.

1. Pedal head rubber
2. Return spring
3. Pedal lever boss
4. Clevis pin
5. Nylon bushing
6. Pedal shaft, etc.

Reinstallation

Reinstall the clutch pedal in reverse sequence of removal.

Adjustment

1. Adjust the pedal head height to 226 mm (8.9 in) for both right-hand and left-hand drive by adjusting the master cylinder push rod length.

Note: The pedal stopper should be free.

2. Adjust the pedal height to 223 mm (8.8 in) by screwing the pedal stopper and lock up the lock nut.

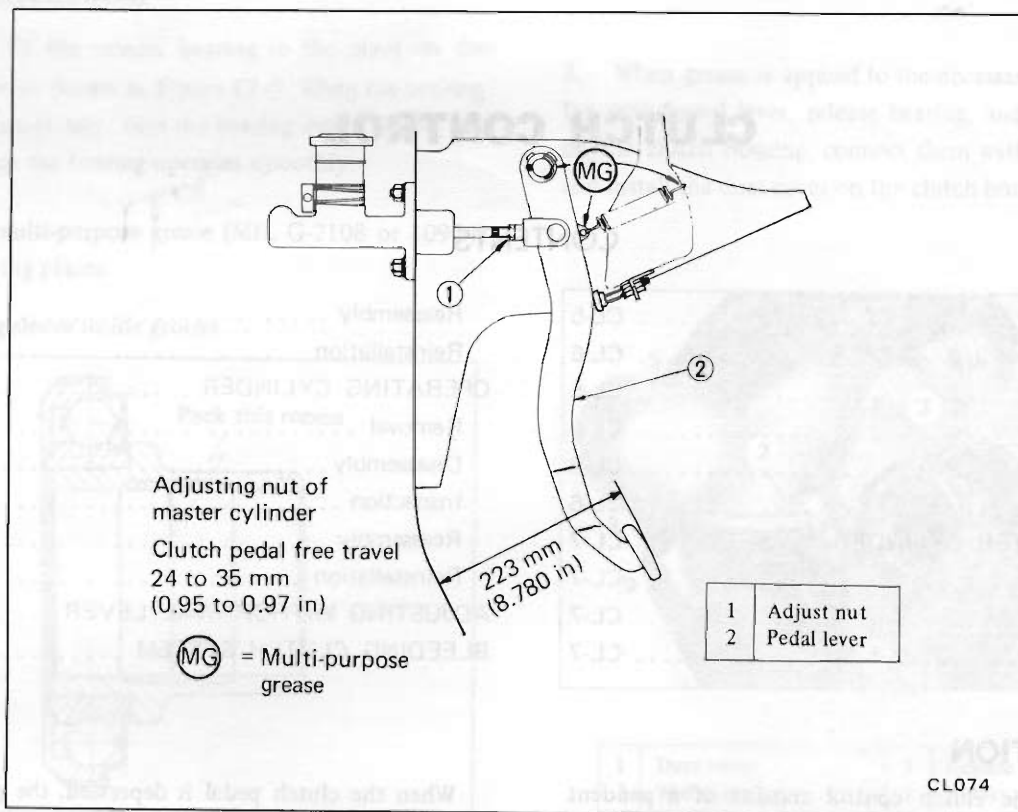

Fig. CL-14 Pedal height adjustment

CLUTCH

CLUTCH MASTER CYLINDER

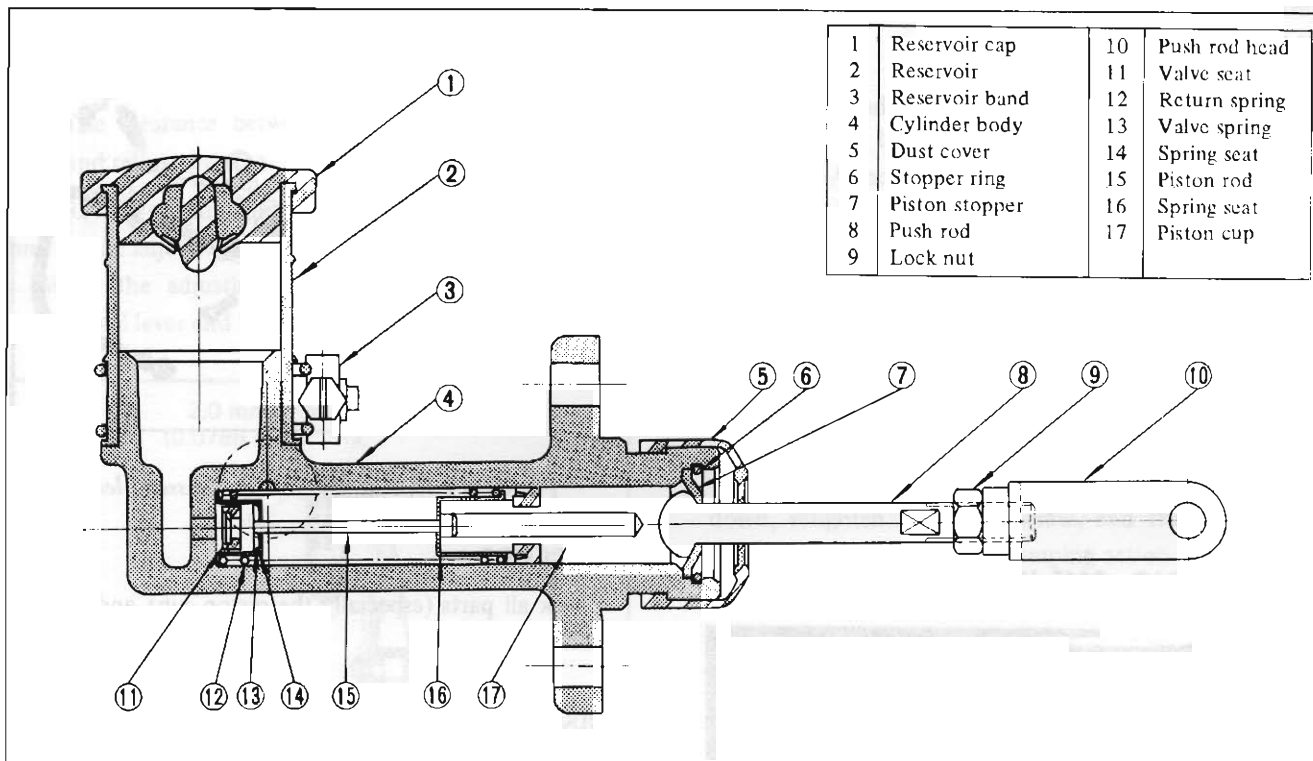

Fig. CL-15 Clutch master cylinder

Removal

1. Loosen the lock nut of the master cylinder push rod and disconnect the push rod from the clevis.
2. Disconnect the clutch line from the master cylinder, and drain fluid.
3. Remove the securing bolts and remove the master cylinder assembly from the vehicle.

Disassembly

1. Remove the filler cap and drain fluid.
2. Pull back the dust cover and remove the snap ring. The stopper, push rod, piston assembly, primary cup and return spring assembly can be removed.

Inspection

Thoroughly clean all parts with brake fluid before inspection.

1. Check the cylinder and piston for uneven wear or damage. Replace if required.

2. When clearance between the cylinder and piston is more than 0.15 mm (0.0059 in), replace the cylinder.

3. Replace the piston cup, primarily, whenever the master cylinder is disassembled. It must also be replaced when wear or deformation due to fatigue or damage is found.

4. Check the dust cover, oil reservoir, filler cap, and clutch line for damage or deformation. If abnormal condition is found, replace with a new one.

Reassembly

Reassemble the master cylinder assembly in reverse sequence of disassembly noting the following matters.

CHASSIS

1. The piston cup should be soaked in brake fluid before reassembly. Install the piston cup carefully so that it is correctly faced.

2. Apply brake fluid sufficiently to the cylinder and piston, and assemble them.

Reinstallation

Reinstall the master cylinder assembly in reverse sequence of removal, and adjust as follows.

1. Adjust the pedal height by changing the push rod length.
2. Bleed air out of the hydraulic system.

OPERATING CYLINDER

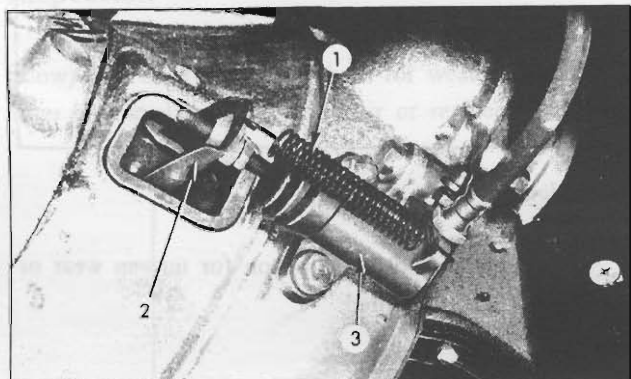

1	Return spring	3	Operating cylinder
2	Withdrawal lever		

Fig. CL-16 Operating cylinder

Removal

1. Remove the return spring.
2. Disconnect the clutch hydraulic line from the operating cylinder.
3. Disconnect the push rod from the withdrawal lever.
4. Release two bolts used to mount the operating cylinder to the clutch housing.

Disassembly

1. Remove the dust cover.

2. Remove the snap ring. All other parts can be disassembled.

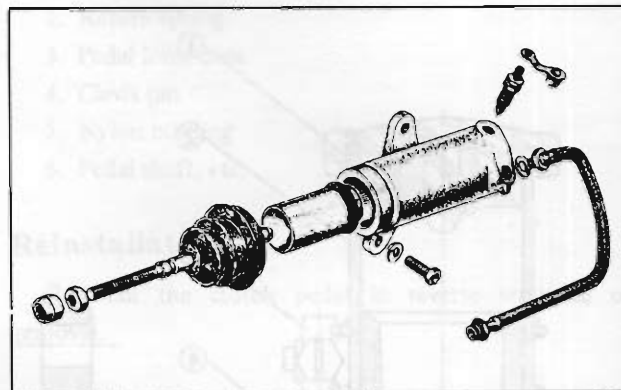

Fig. CL-17 Operating cylinder disassembled

Inspection

Check all parts (especially the piston cup), and replace if worn or damaged.

Reassembly

Reassemble the operating cylinder in reverse sequence of disassembly noting the following matters.

1. Soak the piston cup in fluid before reassembly. Install the piston cup carefully so that it is faced correctly.
2. Apply brake fluid sufficiently to the cylinder and piston, and assemble them.

Reinstallation

Reinstall the operating cylinder in reverse sequence of removal.

1. Bleed air out of the hydraulic system.
2. Adjust the clearance between the top of withdrawal lever and release bearing to 2.0 mm (0.079 in) in accordance with the following instructions.

ADJUSTING WITHDRAWAL LEVER

Correct adjustment of the clutch withdrawal lever is essential. Insufficient free travel between the release bearing and the diaphragm spring fingers causes the clutch to slip, while excessive free travel affects full disengagement of the clutch.

CLUTCH

The clearance between the release bearing and the diaphragm spring fingers can be adjusted at the withdrawal lever end as follows.

1. Loosen the lock nut, tighten the adjusting nut and eliminate clearance between the top of the withdrawal lever and release bearing.
2. Return the adjusting nut from that position 1.5 turns and set the adjusting nut stationarily with the lock nut.

When the adjusting nut is returned 1.5 turns, the withdrawal lever end is returned 2.0 mm (0.079 in).

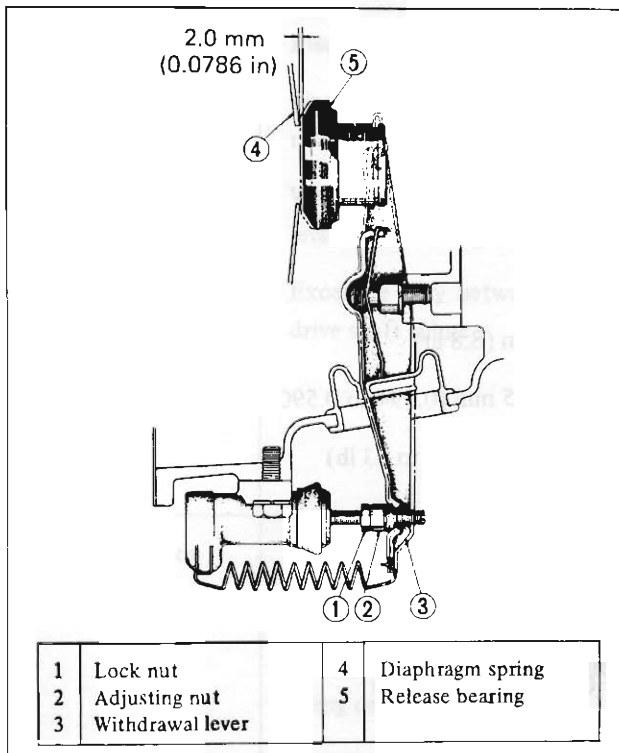

Fig. CL-18 Adjusting withdrawal lever play

BLEEDING CLUTCH SYSTEM

1. Remove the bleed screw dust cap from the operating cylinder.
2. Open the bleed screw approximately three-quarters of a turn. Attach a tube immersing the open end into a clean container which contains a small amount of brake fluid.
3. Fill the master cylinder reservoir with the recommended fluid.
4. Depress the clutch pedal slowly, and while keeping it down, retighten the bleed screw, and then allow it to return slowly. Repeat this pumping action until the fluid entering the container is free from air bubbles.
5. Screw up the bleed screw on a down stroke of the pedal, remove the bleed tube and replace the dust cap.

SERVICE DATA AND SPECIFICATIONS

Clutch release lever

Release bearing-to-diaphragm spring (withdrawal lever) clearance	2.0 mm (0.079 in)
Diaphragm spring-to-flywheel height	43.0 to 45.0 mm (1.693 to 1.772 in)

CHASSIS

Clutch disc

Facing size

Outer dia. x inside dia. x thickness 225 x 150 x 3.5 mm
(8.86 x 5.90 x 0.140 in)

Total friction area 442 cm² (68.51 sq in)

Thickness of disc assembly

Free 8.3 to 8.9 mm (0.327 to 0.350 in)

Compressed 7.6 to 8.0 mm (0.300 to 0.315 in)

Number of torsion springs 6

Allowable minimum depth of rivet head from

facing surface 0.3 mm (0.0118 in)

Allowable facing run-out 0.5 mm (0.0197 in)

Allowable free play of spline 0.4 mm (0.0157 in)

Clutch pedal

Pedal height when not depressed 223 mm (8.8 in)

Free travel of pedal head 10 to 15 mm (0.394 to 0.590 in)

Pressing strength at full stroke 10 to 15 kg (22 to 33 lb)

Master cylinder – clutch

Master cylinder diameter 15.87 mm (5/8 in)

Allowable maximum clearance between
cylinder and piston

..... 0.15 mm (0.0059 in)

Operating cylinder – clutch

Operating cylinder diameter 17.46 mm (11/16 in)

Tightening torque

Clutch assembly securing bolt 1.5 to 2.2 kg-m (11 to 16 ft-lb)

CLUTCH

TROUBLE DIAGNOSES AND CORRECTIONS

Troubles	Possible causes	Corrective action
Noises audible on pedal depression	<p>Excessively worn, damaged or poorly lubricated release bearing</p> <p>Seized release bearing and diaphragm spring fingers</p> <p>Insufficient pedal free travel</p> <p>Weakened, unhooked or broken clutch pedal return and control springs</p> <p>Weakened, unhooked or broken clutch yoke lever return spring</p> <p>Excessive play between clutch disc hub and drive shaft spline</p>	<p>Replace the bearing which, being cased, cannot be greased inside.</p> <p>Replace the release bearing. Clean diaphragm spring fingers with metal brush and smooth out bearing contact faces with felt polishers.</p> <p>Readjust pedal free travel correctly.</p> <p>Set springs in position, or replace them if weakened or snapped.</p> <p>Replace the spring or hook it up, as required.</p> <p>Replace the clutch disc and ensure that clearance between hub of new clutch and drive shaft is within 0.50 mm (0.0197 in) endwise and 0.20 to 0.0079 in) crosswise. When clearances exceed above limits, replace the drive shaft also.</p>
Noises audible on pedal release	<p>Misalignment of clutch disc to flywheel causes slight movement of disc hub in respect of facings. This noise is especially audible with engine idling or at low speed.</p> <p>Broken or weakened clutch disc cushion springs</p> <p>Insufficient pedal free travel</p> <p>Weakened, unhooked or broken clutch controlled pedal return springs</p> <p>Weakened, broken or unhooked clutch yoke lever return spring</p> <p>Distorted or worn drive shaft</p> <p>Excessive play of release bearing on slip sleeve</p>	<p>Set level of clutch disc with clutch disc in place on drive shaft, set it under slight rotation and check for no run-out, using a scriber.</p> <p>Replace the clutch disc.</p> <p>Set pedal free travel correctly.</p> <p>Replace the spring or hook it up, as required.</p> <p>Replace the spring or hook it up, as required.</p> <p>Replace the drive shaft and clutch disc if necessary.</p> <p>Replace the worn parts.</p>

CHASSIS

<p>The clutch drags.</p>	<p>Insufficient push rod length</p> <p>Excessive pedal free travel</p> <p>Warped clutch disc</p> <p>Roughened linings</p> <p>Improperly fitted, loose or broken lining</p> <p>Incorrect release bearing-to-diaphragm spring finger clearance</p> <p>Clutch disc hub forcing on drive shaft</p> <p>Damaged drive shaft splines prevent the clutch disc from sliding</p> <p>Oil or grease on linings</p> <p>Warped or damaged pressure plate or clutch cover</p> <p>Air pockets in the hydraulic system (not bled correctly)</p> <p>Dirt or foreign matter on sealing faces of master cylinder piston cup</p> <p>Air pockets in master cylinder due to loose piston</p> <p>Fluid leakage from cylinder</p> <p>Low fluid level in reservoir</p> <p>Clogged vent hole in reservoir cap promotes vacuum in master cylinder allowing air to infiltrate past the seal</p>	<p>Adjust the push rod length correctly.</p> <p>Adjust free travel correctly</p> <p>Repair or replace. Maximum plate run-out; 0.25 mm (0.0098 in)</p> <p>Repolish linings with a metal brush or replace them, if necessary.</p> <p>Replace linings. Lining rivets should be clenched with no protrusion, to avoid damaging pressure plate and flywheel.</p> <p>Adjust correctly.</p> <p>Locate cause of trouble and remove it, if possible. Otherwise replace the clutch disc.</p> <p>Replace the drive shaft; also the clutch disc, if required.</p> <p>Locate the cause of oil or grease leakage and correct it as required. Clean or replace linings.</p> <p>Replace defective parts.</p> <p>Bleed out completely.</p> <p>Clean, replace piston cup, if damaged, and bleed the system.</p> <p>Replace piston cup and bleed the system.</p> <p>Replace piston cup, if damaged; bleed the system.</p> <p>Top up with brake fluid and bleed the system, if necessary.</p> <p>Clean reservoir cap, unclog the vent hole and bleed the system.</p>
<p>Abnormal lining wear</p>	<p>Insufficient pedal free travel</p>	<p>Adjust clutch pedal free travel correctly.</p>

CLUTCH

	<p>Driver steps unnecessarily on pedal; this causes lining wear and damage to release bearing</p> <p>Weakened or snapped pressure springs</p> <p>Incorrectly installed linings</p>	<p>Advise driver to discontinue wrong practice and step on clutch pedal only when necessary.</p> <p>Check pressure springs for tension as specified, and replace springs, if they are un-serviceable.</p> <p>Replace linings with new ones and install them correctly. Check clutch disc for center alignment.</p>
The clutch grabs.	<p>Oil or grease on flywheel, pressure plate and linings</p> <p>Loose disc linings due to poor rivet tightness</p> <p>Clutch disc hub does not slide freely on drive shaft spline</p> <p>Warped or cracked pressure plate</p> <p>Misalignment</p> <p>Stiffened hydraulic control mechanism</p> <p>Worn out lining</p>	<p>Remove cause of leakage, clean flywheel and pressure plate thoroughly, replace linings.</p> <p>If linings are not worn, replace defective rivets. Otherwise, replace linings and clench rivets securely.</p> <p>Remove any foreign matter or dirt deposits from shaft splines. When trouble is still present, replace damaged part.</p> <p>Replace pressure plate.</p> <p>Locate the defective point, and if possible, adjust alignment or replace distorted parts.</p> <p>Check spring tension: If necessary, take down pedal and lubricate components.</p> <p>Install new linings and make sure that the clutch disc, pressure plate and flywheel are not damaged.</p>
The clutch slips.	<p>Insufficient clutch pedal return travel, due to the control and pedal return springs being weak or misadjusted</p> <p>Weakened or broken diaphragm spring</p> <p>Oil or grease on linings</p> <p>Worn or burned disc linings</p> <p>Overloaded master cylinder due to a restricted transfer port</p>	<p>Locate cause of failure and replace defective springs.</p> <p>Overhaul clutch and replace spring.</p> <p>Remove cause of leakage and replace linings if cleaning is ineffective.</p> <p>Replace linings.</p> <p>Overhaul the master cylinder, replace the piston cup if swollen or damaged, and clean the transfer port; bleed the system.</p>

CHASSIS

SERVICE JOURNAL OR BULLETIN REFERENCE

DATE	JOURNAL or BULLETIN No.	PAGE No.	SUBJECT